

Dehumidifier WDH-520EB

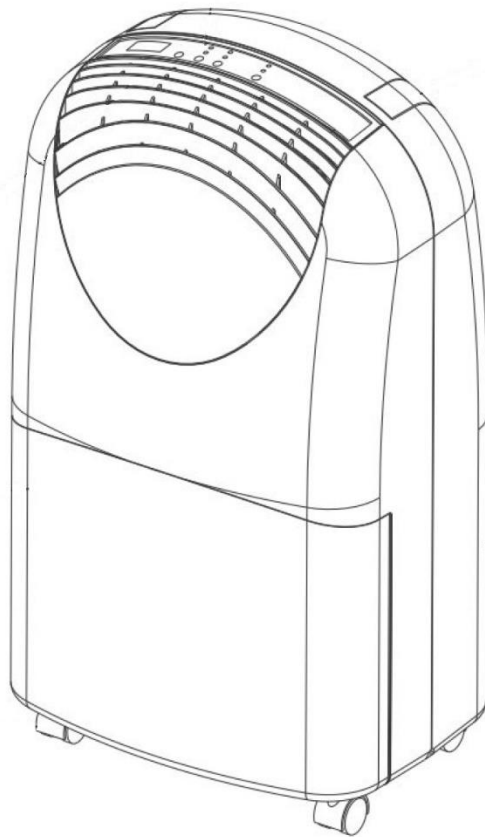

Dear Customer,

You have chosen a high-quality product. To ensure that you get a lot of enjoyment from this product, here are a few more tips:

After transport:

Since the unit works with refrigerant, improper transport can sometimes occur despite careful instructions on the carton. For this reason, we ask you to leave the unit upright for at least 4 hours before using it for the first time. 4 hours before using the unit for the first time, so that the refrigerant can settle properly in the unit.

In case of any problems:

We hope that the unit meets your expectations! If, despite the greatest possible care, there should ever be cause for complaint, please contact us briefly, as we are very concerned about your satisfaction and would like to clear up any misunderstanding.

During the first operation:

As the internal piping comes into contact with moisture for the first time, it can take up to approx. 3 hours for the first liquid to accumulate in the collection container, depending on the humidity.

Start-up time / delay:

To protect the compressor, the unit does not switch on again immediately after it has stopped operation or there has been an interruption in operation (e.g. emptying the condensation tank), but is first in a so-called "protection mode" for approx. 3 minutes, during which neither the fan nor the compressor run. The green operating light (running LED) also only switches on again after the protection/waiting time has elapsed.

Room humidity and dehumidification performance:

If you want to check the room humidity and the associated dehumidification performance with your own humidity meter (hygrometer), please avoid attaching this humidity meter to a wall, as this will falsify the true humidity content of the room air. See also the explanations under Troubleshooting !!!

Important safety instructions:

- When assembling, using and cleaning, follow the operating instructions strictly and read them very carefully !
- Supervise the dehumidifier when children are near the appliance !
- Watch out for electricity, never walk into or insert objects into the appliance !
- Do not place any objects on the dehumidifier !
- Do not block the exhaust air fins of the unit and please ensure sufficient space/clearance at and around the fan !
- Ensure that there is sufficient air supply to the unit, otherwise it can lead to a reduction in performance and, in the worst case, to overheating and/or fire !
- Make sure that no moisture gets to the electrics of the unit !
- Only use the recommended voltage for operating the unit !
- Make sure that the power cable is unfolded (untied) before connecting it to the socket !
- Make sure that the plug is cleanly and properly connected to the socket before using the appliance !
- In case of problems or damage, always contact the manufacturer immediately and never repair it yourself !
- Never reach near the plug or socket with wet hands !
- Please do not use multiple sockets for operating the dehumidifier !
- Do not repair defective or damaged cables on the unit yourself, you could get a severe electric shock !
- Make sure that highly flammable substances (e.g. gases/oils etc.) are never in the vicinity of the unit !
- If you are not going to use the unit for a long time, switch it off and disconnect the mains plug !
- This appliance is not intended to be used by persons (including children) with reduced physical, sensory or mental capabilities, or lack of experience and/or knowledge, unless they have been given supervision or instruction concerning use of the appliance by a person responsible for their safety.
- Do not make any changes to the unit !
- The dehumidifier should not be operated or stored in a room with other burning/heating appliances !

Please switch off the unit immediately and disconnect it from the mains/power supply if anything seems to be wrong !!! In this case, please contact a specialist and do not attempt to repair the unit yourself !!!

Examples: Fan does not run during operation, fuse has blown or compressor rattles loudly.

Important operating and safety instructions regarding the refrigerant R290 in this unit:

- Read these instructions carefully and observe them strictly !
- The unit operates with the refrigerant R290. This refrigerant is highly flammable and explosive if the safety instructions are not observed!
- The unit should not be stored or operated in a room with burning/heating appliances or open fire !
- Please note that the refrigerant is odourless and therefore a leak cannot be detected immediately by an emerging odour !
- Make sure that the outlet of the exhaust air is always ensured and not obstructed by other objects !
- Ensure a minimum distance of at least 50 cm from open flames and heating elements !
- Set-up, operation and storage of the unit should take place in a room with a minimum size of 4 m²!
- When cleaning, proceed strictly according to the manufacturer's instructions and do not use any additional heat sources to possibly accelerate the defrosting process of the appliance !

This unit has parts that must not be replaced or repaired !

The refrigerant cannot be renewed or replaced !

Do not carry out any independent repairs or modifications to your unit !

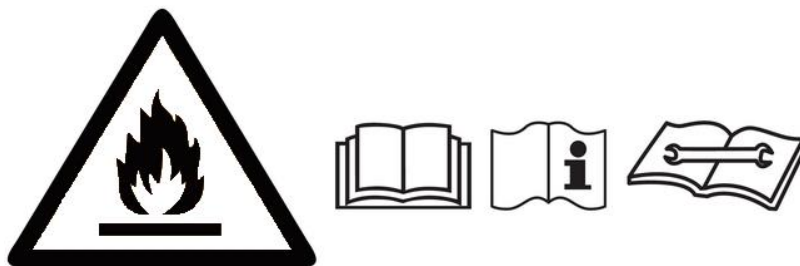

Important safety instructions for repairing an appliance with R290 refrigerant:

1. Check the environment

Before you start working on systems containing flammable refrigerants, safety checks are required to ensure that the risk of ignition is minimized. When repairing the refrigerant system, the following safety precautions must be observed and complied with before any work is carried out on the system.

Procedure

The work must be carried out under a controlled procedure to minimize the risk of flammable gases or vapours being present during the work.

2. General work area

All maintenance personnel and other persons in the vicinity must be instructed on the type of work to be carried out. Work in confined spaces must be avoided. The area around the work area must be cordoned off. Ensure that the conditions in the work area have been made safe by checking the flammable material.

3. Check for the presence of refrigerants

The area must be checked with a suitable refrigerant detector before and during the work to ensure that the technician is aware of possible flammable atmospheres. Ensure that the refrigerant detector used is suitable for working with flammable refrigerants, e.g. non-sparking, adequately sealed and intrinsically safe.

4. Presence of a fire extinguisher

If hot work is to be carried out on the refrigerant equipment or associated parts, suitable fire extinguishing equipment must be readily available. Ensure that a dry powder fire extinguisher or a CO2 fire extinguisher is nearby.

5. No ignition sources

Persons carrying out work in connection with a refrigerant system which involves exposure to piping containing or having contained flammable refrigerant must use ignition sources in such a way that they cannot cause a fire or explosion hazard. All possible ignition sources, including cigarette smoking, should be kept sufficiently away from the site of installation, repair and disposal during which the flammable refrigerant may be released into the surrounding area. Prior to work, the area around the equipment must be inspected to ensure that there are no flammable hazards or ignition risks. "No Smoking" signs must be posted.

6. Ventilated area

Ensure that the work area is outdoors or adequately ventilated before interfering with the system or performing hot work. Sufficient ventilation must be ensured for the entire duration of the work to be carried out. The ventilation should safely disperse any released refrigerant and preferably discharge it externally to the atmosphere.

7. Testing the refrigerant equipment

When electrical components are replaced, they must be fit for purpose and of the correct specification. The manufacturer's guidelines for maintenance and repair must be observed and followed at all times. If in doubt, contact the manufacturer's technical department for assistance.

The following checks must be applied to installations containing flammable refrigerants:

- The charging quantity is in accordance with the room size within which the refrigerant containing parts are installed;
- The ventilation equipment and the ventilation outlets are running properly and are not blocked.

8. Checking the electrical equipment

Before repairing and maintaining electrical components, preliminary safety checks and inspection procedures must be carried out on the components. If there is a defect that could jeopardize safety, the appliance must not be connected to the power supply until the defect has been rectified. If the defect cannot be rectified immediately but operation must continue, an adequate temporary solution must be found. This must be reported to the owner of the equipment so that all parties are informed.

The preliminary safety checks must include

Capacitors must be discharged; this should be done in a safe manner to avoid the possibility of sparking.

No live components or wiring shall be exposed when filling, restoring or flushing the system. Continuity of the earth connection.

9. Repairs to hermetically sealed components

During repairs to hermetically sealed components, all power to the appliance must be disconnected before removing sealed covers etc. If it is essential that power is supplied to the appliance during maintenance, a permanent leak detection system must be in place to warn of a potentially dangerous situation.

Particular attention must be paid to the following point to ensure that when working on electrical components, the housing is not modified in such a way that the degree of protection is impaired. This includes damage to cables, an excessive number of connections, terminals that do not meet the original specification, damage to seals, improper fitting of sealing screws, etc. Ensure that the appliance is securely mounted.

Ensure that seals or sealing material are not so worn that they no longer serve their purpose to prevent the ingress of flammable atmospheres. Replacement parts must be in accordance with the manufacturer's specifications.

NOTE: The use of silicone sealants may hinder the effectiveness of some leak detectors. Intrinsically safe components do not need to be sealed before working on them.

10. Repair of intrinsically safe components

Do not apply a permanent inductive load or capacitance load to the circuit without ensuring that it does not exceed the allowable voltage and current for the equipment being used. Intrinsically safe components are the only types that can be worked on while connected to the mains in the presence of a flammable atmosphere. The test equipment must have the correct ratings. Replace components only with parts specified by the manufacturer. Other parts may cause the refrigerant to ignite in the atmosphere due to a leak.

11. Wiring

Check that the wiring is not subject to wear, corrosion, excessive pressure, shocks, sharp edges or other harmful environmental effects. The test must also take into account the effects of ageing or continuous vibration from sources such as compressors or fans.

12. Detection of flammable refrigerants

Under no circumstances should potential ignition sources be used when searching for or detecting refrigerant leaks. A halogen search lamp (or any other search device that uses naked flames) must not be used.

13. Leak detection methods

The following leak detection methods are considered acceptable for systems containing flammable refrigerants.

Electronic leak detectors must be used to detect flammable refrigerants, but their sensitivity may not be sufficient or they may need to be recalibrated. (Detection equipment must be calibrated in a refrigerant-free area.) Ensure that the leak detector is not a potential ignition source and that it is suitable for the refrigerant used. Leak detection equipment must be set to a percentage of the lower explosion limit and must be calibrated to the refrigerant used and the adequate percentage of the gas (25% maximum) must be confirmed.

Leak detection fluids are suitable for use with most refrigerants, but the use of cleaning agents containing chlorine must be avoided as chlorine can react with the refrigerant and degrade the copper piping.

If a leak is suspected, remove/extinguish all naked flames.

If a refrigerant leak is detected that requires brazing, all refrigerant must be recovered from the refrigeration system or isolated (by shutting off valves) in a part of the system remote from the leak. Oxygen-free nitrogen must then be purged through the system before and during the brazing process.

14. Removal and draining

When intervening in the refrigerant circuit to carry out repairs - or for any other reason - conventional methods must be used. However, it is important that best practice is always followed, as flammability must be taken into account. The following procedure should be followed:

- Remove the refrigerant
- Purge the circuit with inert gas
- Deflate the circuit
- Purge again with inert gas
- Open the circuit by cutting or brazing

The refrigerant charge must be prepared in the correct preparation cylinders. The system must be "purged" with oxygen-free nitrogen to keep the appliance safe. This process may need to be repeated several times. Compressed air or oxygen must not be used for this purpose.

Purging can be achieved by intervening in the vacuum in the system with oxygen-free nitrogen and continuing to fill until the working pressure is reached and then releasing to atmosphere and finally drawing into a vacuum. This process must be repeated until there is no more refrigerant in the system. When the last filling with oxygen-free nitrogen takes place, the system must be vented to atmospheric pressure. This is absolutely necessary if soldering work has to be carried out on the pipework. Make sure that the outlet for the vacuum pump is not near any ignition sources and that ventilation is available.

15. Filling process

In addition to conventional filling procedures, the following requirements must be followed:

- Ensure that no contamination of the various refrigerants occurs when filling the equipment. Hoses or cables must be as short as possible to minimize the amount of refrigerant they contain.
- Cylinders must remain upright.
- Ensure that the refrigeration system is earthed before charging the system with refrigerant.
- Mark the system when charging is complete (if not already done).
- Extreme care must be taken not to overfill the cooling system.

Before refilling the system, the pressure must be tested with oxygen-free nitrogen. The system must be tested for leaks at the end of filling but before commissioning. A check leakage test must be carried out before leaving the site.

16. Decommissioning

Before carrying out this procedure, it is necessary that the technician is fully familiar with the equipment and its details. It is a recommended standard that all refrigerants are safely reconditioned. An oil and refrigerant sample must be taken prior to the task to be carried out in case analysis is required prior to reuse of the reclaimed refrigerant. It is necessary that electrical power is available before the task is started.

- Familiarize yourself with the equipment and its operation.
- Disconnect the system electrically.
- Before carrying out the operation, make sure that mechanical handling equipment is available; if necessary also for handling refrigerant cylinders.
handling of refrigerant cylinders;
that personal protective equipment is available and properly worn;
that the reprocessing operation is supervised at all times by a competent person;
that the reprocessing equipment and cylinders comply with the applicable standards.
- Pump down the refrigerant system if possible.
- If a vacuum is not possible, establish a manifold so that the refrigerant can be removed from the various parts of the system.
- Make sure that the cylinder is straight and stable.
- Start the conditioning system and operate it according to the manufacturer's instructions.
- Do not overfill the cylinders (no more than 80 % liquid filling capacity)
- Do not exceed the maximum working pressure of the cylinder, not even temporarily.
- When the cylinders have been properly charged and the process is complete, ensure that the cylinders and equipment are immediately removed from site and that all shut-off valves on the equipment are closed.
- Reconditioned refrigerant must not be charged into other refrigeration systems unless it has been cleaned and tested.

17. Labeling

The equipment must be marked to show that it has been taken out of service and that the refrigerant has been drained. The marking must be dated and signed. Ensure that there are markings on the equipment stating that the equipment contains flammable refrigerant.

18. Reconditioning

When removing refrigerant from a system, either for servicing or decommissioning, it is recommended standard practice that all refrigerant is safely removed. When transferring refrigerant to cylinders, ensure that only suitable refrigerant reprocessing cylinders are used. Ensure that the correct number of cylinders are available to hold the total amount of refrigerant. All cylinders used must be suitable and marked for the reconditioned refrigerant (i.e. special cylinders for reconditioning refrigerant). The cylinders must have a pressure relief valve and a connected shut-off valve and be in good working condition. Empty reprocessing cylinders must be emptied of air and, if possible, cooled before reprocessing.

The reprocessing plant must be in good working order with appropriate instructions concerning the equipment and must be suitable for the reprocessing of flammable refrigerants. In addition, a set of calibrated scales in good working order must be available. Hoses must be complete with leak-free and proper disconnect couplings. Before using the reconditioner, check that it is in good working order, that it has been properly maintained and that all associated electrical components are sealed to prevent ignition in the event of a refrigerant leak. If in doubt, contact the manufacturer.

The reconditioned refrigerant must be returned to the refrigerant supplier in the correct reconditioning cylinder and the appropriate proof of disposal must be arranged. Do not mix refrigerants in remanufacturing units and especially not in cylinders. If a compressor or compressor oils are to be removed, ensure that they have been evacuated to an acceptable level to ensure that no flammable refrigerant remains in the lubricant. The evacuation process must be carried out before returning the compressor to the supplier. Only electrical heating of the compressor housing may be used to accelerate this process. When draining oil from a system, this must be done in a safe manner.

Description of the unit parts:

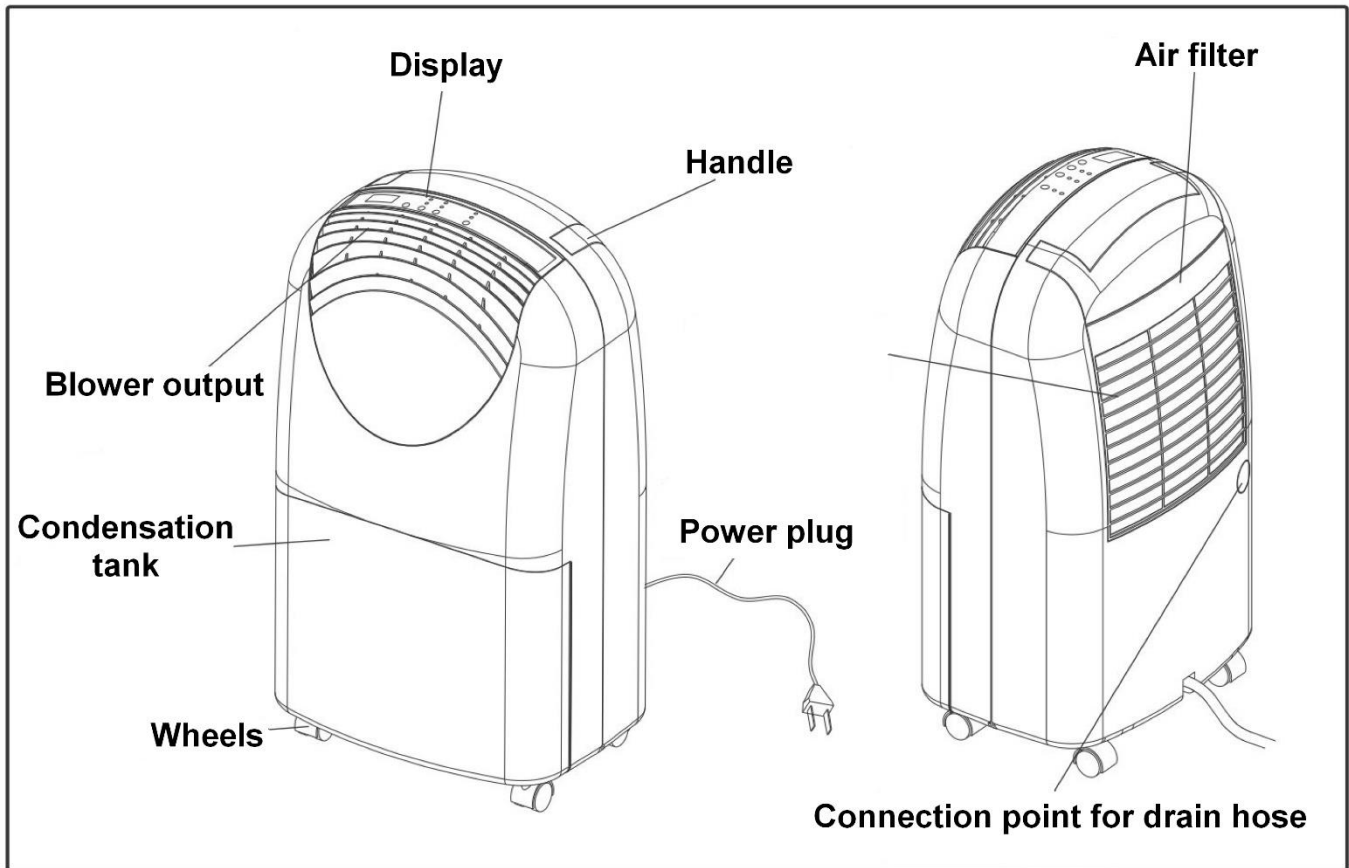

Functional description:

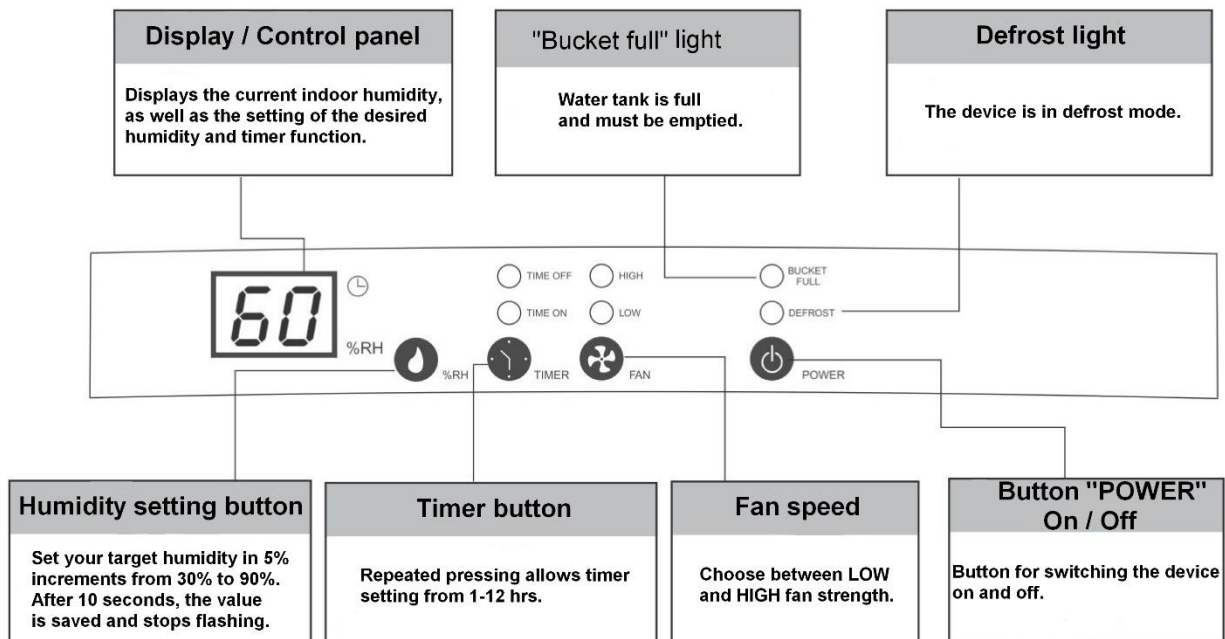

Instructions for use:

1. Commissioning

- 1.1 Insert the mains plug properly into the socket.
- 1.2 Check that the condensation tank is properly seated in the dehumidifier. (When using the dehumidifier for the first time, the "condensation tank full" light may come on. Simply pull the condensation tank out briefly and then push it right back in and you are ready to go).
- 1.3 Switch on the unit with the power switch. Now press the humidity setting button and set your target humidity as desired. The target value of 30% humidity actually corresponds to continuous operation ! The value you set must be below the current room humidity for the unit to dehumidify. If your value is above the current room humidity, the fan runs for 3 minutes and the unit then switches off. If the room humidity rises above the set value, the unit automatically starts dehumidifying again.
- 1.4 Select between a low and a high fan strength / air circulation with the "FAN" button.
- 1.5 If you want to activate/use the timer function (function for determining the remaining time or function for specifying a start time), press the TIMER key.

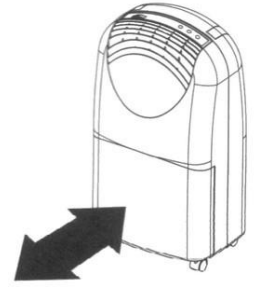

Determining the remaining running time: Press the TIMER button during operation to select the desired remaining running time of the dehumidifier. (A value between 1 - 12 hours can be selected). After this selected operating time has elapsed, the unit switches off automatically.

Determining a start time: When the dehumidifier is switched off, press the TIMER button to select the desired start time. (A value between 1 - 12 hours can be selected). After this selected time has elapsed, the appliance switches on automatically (with the last settings used, provided the mains plug has not been disconnected in the meantime).

2. Emptying the collection tank / When the "Bucket Full" light is on

When the condensation tank is full, the signal light lights up and the dehumidifier then automatically stops its dehumidification operation. Remove the condensation tank and empty it. After you have pushed the condensation tank neatly back into the unit, the dehumidification operation starts again automatically.



3. Connecting a hose

- 3.1 You will need a ½ inch plastic hose.
- 3.2 Briefly remove the condensation tank and push out the pre-punched plastic cover (connection point for drain hose) with a large screwdriver.
- 3.3 Pass the plastic hose through the rear opening and then connect it to the drip tap (see diagrams below). Then push the condensation tank neatly back into the appliance.

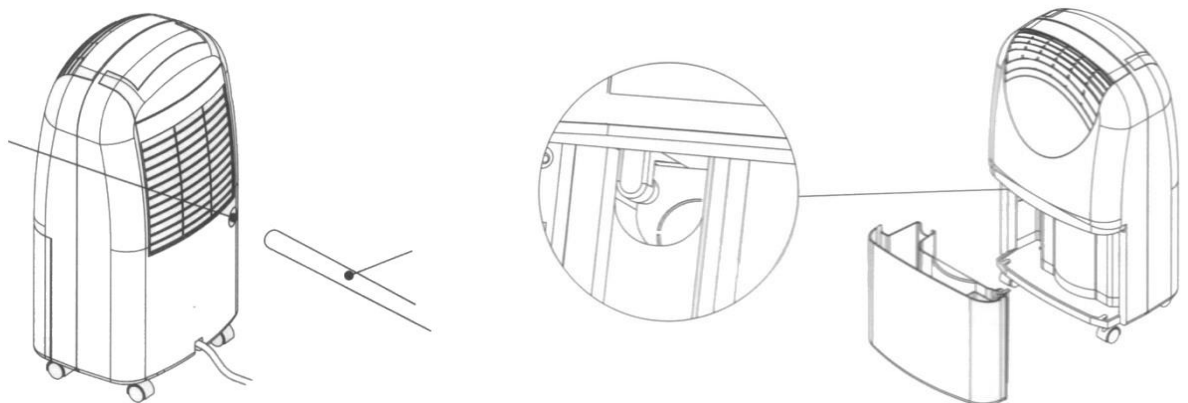

3.4. Proper drainage of condensation water with hose connection ! Make sure that the hose always has a slight slope (see the following diagrams).

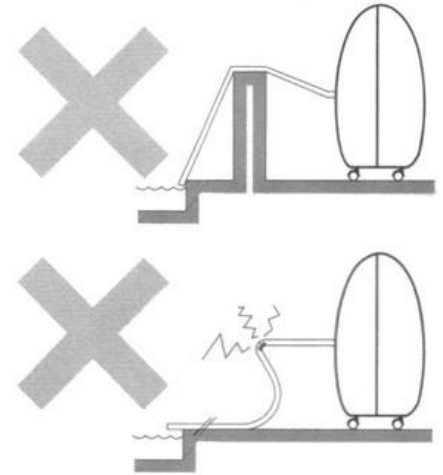
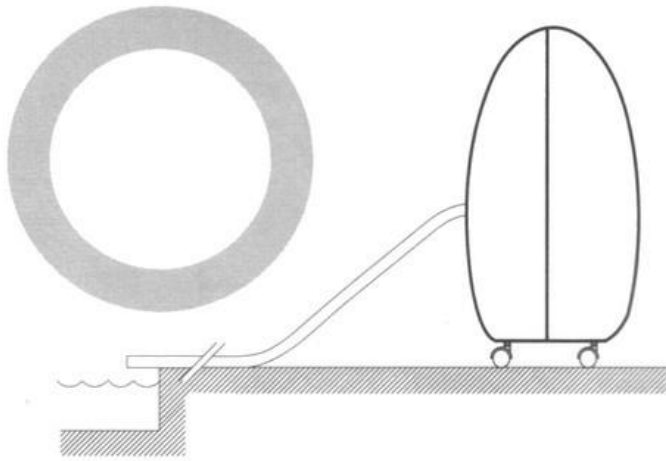

4. Other operating instructions

- 4.1. Do not disconnect the mains plug by pulling on the power cable !
- 4.2. Do not use insect, oil or paint spray etc. near the dehumidifier. This may cause damage to the unit or even fire !
- 4.3. Do not place the appliance on sloping or uneven ground !
- 4.4. Please always keep a distance of approx. 20 cm to the wall to avoid possible overheating of the appliance. Furthermore, please also ensure a distance of approx. 50 cm upwards when drying laundry !
- 4.5. For effective and economical dehumidification operation, please close all doors and windows in the dehumidifier room !
- 4.6. Please keep the unit away from heat sources !
- 4.7. Always keep the appliance in its proper and upright position and transport !

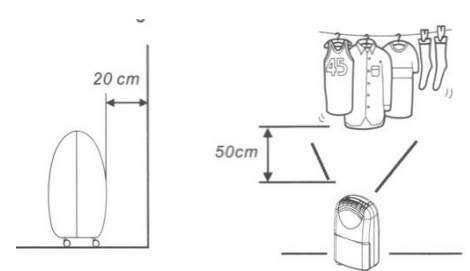
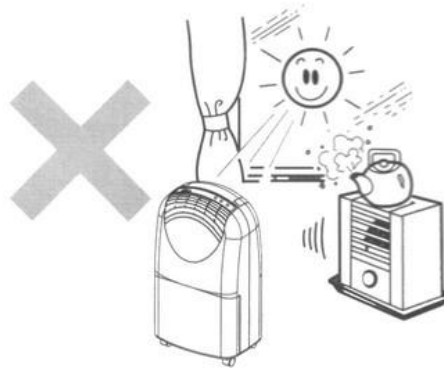
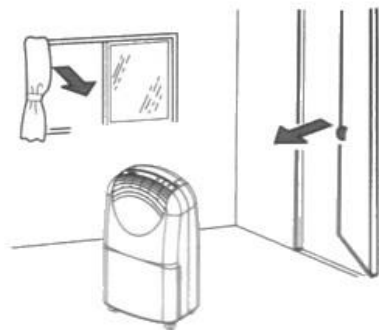
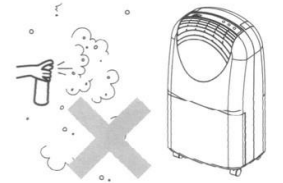
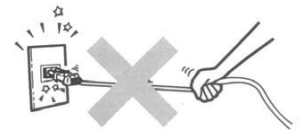

5. Cleaning

5.1 Cleaning the housing

- Please unplug the dehumidifier from the mains before cleaning.
- Only use mild cleaning agents to clean your dehumidifier.
- NEVER spray your dehumidifier (e.g. with water or similar).

5.2 Cleaning the air filter

The air filter filters lint, hair and coarse dust. The air filter is coated with an antibacterial glaze to inhibit the proliferation of bacteria. Furthermore, the air filter ensures that less dust is deposited on the cooling fins, thus ensuring higher efficiency.

- Clean the filter whenever it can be assumed that the air intake is reduced by the dirty air filter !
- Fold the carrying handle upwards and then remove the air filter, upwards, from its holder.
- It is best to clean the air filter carefully under lukewarm water or with a low-setting (suction power) Hoover.
- Push the cleaned air filter back into its holder from above - DONE.

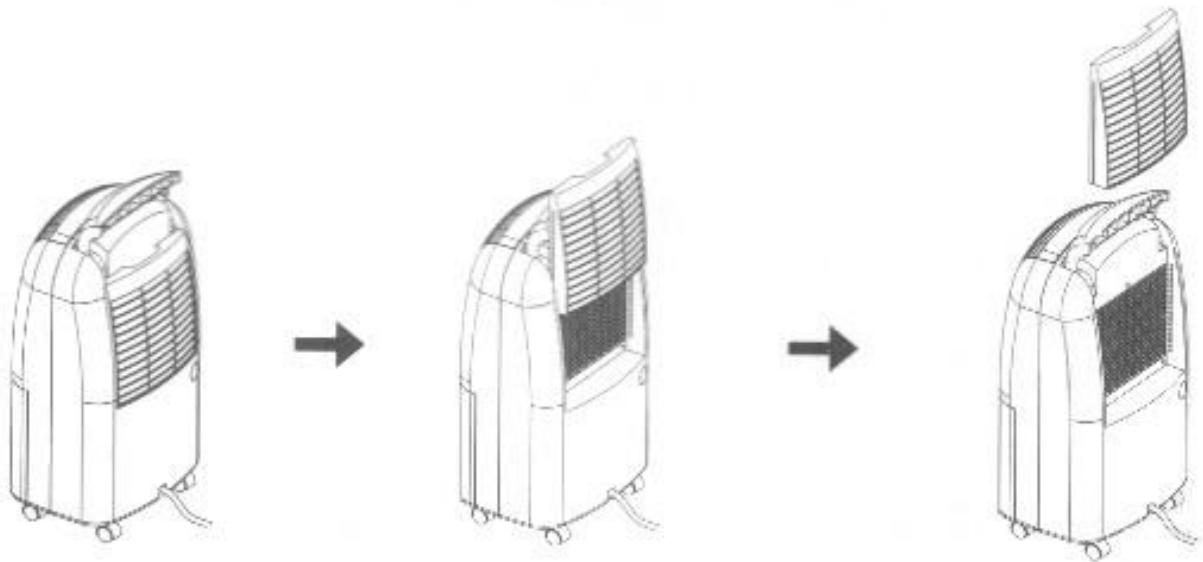

Technical data:

Model name:	WDH-520EB
Voltage:	220 ~ 240V / 50Hz
Max. Power consumption:	505 W
Compressor:	Rotary compressor
Dehumidification capacity (optimal):	25 ltr. /day (35°C / 90% r.h.)
Dehumidification capacity (standard):	20 ltr. /day (30°C / 80% r.h.)
Condensation tank:	Approx. 5 litres
Refrigerant:	R290 (115 g)
Protection class:	IPX0
Dimension (H/W/D):	621 x 345 x 261 mm
Weight:	13 kg
Range of use:	5°C ~ 32°C

Troubleshooting:

The unit does not dehumidify enough / Too little water collects in the condensation tank

Please remember that the primary aim is not to gain as much condensation water as possible, but to dry and/or keep dry the room air or ceilings, walls and inventory !

Furthermore, bear in mind that the dehumidifier can only remove moisture from the air and only indirectly from materials. Depending on the condition of the ceilings, walls and fixtures, it may take several weeks for the stored moisture to be released back into the air! For this reason, we also recommend that if you use your own humidity meter (hygrometer), it should be placed as freely as possible and somewhat away from walls and ceilings, because otherwise the measured humidity value of the room air will be falsified!

As with all dehumidifiers, the dehumidification performance is decisively influenced by the following factors:

A) humidity content of the room air and B) heat/temperature in the room.

Therefore, for safety's sake, here is an excerpt from the dehumidification table at DAUERBETRIEB:

35 degrees and <u>80% r.h.</u> = approx. 22 litres	and at <u>90% r.h.</u> = approx. 25 litres	and at <u>60% r.h.</u> = approx. 13 litres
30 degrees and <u>80% r.h.</u> = approx. 20 litres	and at <u>90% r.h.</u> = approx. 22 litres	and at <u>60% r.h.</u> = approx. 11 litres
20 degrees and <u>80% r.h.</u> = approx. 11 litres	and at <u>90% r.h.</u> = approx. 14 litres	and at <u>60% r.h.</u> = approx. 7 litres
15 degrees and <u>80% r.h.</u> = approx. 9 litres	and at <u>90% r.h.</u> = approx. 11 litres	and at <u>60% r.h.</u> = approx. 5 litres
10 degrees and <u>80% r.h.</u> = approx. 6 litres	and at <u>90% r.h.</u> = approx. 8 litres	and at <u>60% r.h.</u> = approx. 4 litres
5 degrees and <u>80% r.h.</u> = approx. 5 litres	and at <u>90% r.h.</u> = approx. 6 litres	and at <u>60% r.h.</u> = approx. 3 litres

All data are approximate per day (fluctuation tolerance) when measured directly at the unit inlet and, of course, these values only apply if the temperature and moisture content remain constant!

The unit rattles or makes running noises

Running noises are usually caused by the air filter unit. We kindly ask you to remove the air filter and check whether the running noises are still present to the same extent ?

An unfavourable position of the dehumidifier is often the reason for higher running noises. Try changing the position of the dehumidifier a little, as the running noises will usually disappear for the most part. Optimal and particularly quiet operation is achieved when the dehumidifier is placed on a piece of carpet, doormat or similar during operation! (Stone floors, tiles, laminate or parquet, on the other hand, increase the operating noise of the dehumidifier!)

The appliance is leaking or water is leaking out.

In this context, we would like to provide you with the following information:

A "leak" on your dehumidifier is actually impossible, unless the main frame is broken and such a thing can of course be ruled out without force.

If the water still leaks out, then the condensate is probably coming from the "emergency drain", which is located behind the collection container at the very top right in a small triangular recess. The reason for this is that the normal drain is prevented. This can have the following causes:

1. The most common cause is a slight soiling in the drip tray or the left drain (e.g. due to dead insects, dirt or similar) and therefore the condensate cannot drain off normally. In this context, please check the left drain once or shake the unit once briefly in the upside-down position. Make sure that you then wait at least 4 hours before switching the unit on again!
2. The unit does not have a straight stand.
3. It may be that only a large piece of ice has come off the cooling fins of your dehumidifier and this leads to a short-term blockage. We therefore recommend that you disconnect the unit completely from the power supply for a day and then the unit should no longer "leak".

Other:**Warranty statement:**

Notwithstanding the statutory warranty claims, the manufacturer grants a warranty in accordance with the laws of your country, but at least 1 year (in Germany 2 years for private individuals). The warranty begins on the date of sale of the appliance to the end user.

The warranty only covers defects that are due to material or manufacturing faults.
are.

Warranty repairs may only be carried out by an authorised customer service. To

To make your warranty claim, please enclose the original sales receipt (with date of sale).

Excluded from the guarantee are:

- Normal wear
- Improper applications, such as overloading the appliance or non-approved accessories.
- Damage due to external influences, use of force or foreign objects
- Damage caused by non-observance of the operating instructions, e.g. connection to an incorrect mains voltage or non-observance of the assembly instructions.
- Completely or partially dismantled units

Conformity:

The dehumidifier has been tested and itself and/or parts thereof have been manufactured under the following (safety) standards:

TÜV Rheinland "GS" tested, and of course with CE conformity and EMC conformity.

Tested safety according to: EN 60335-2-40:2003+A11+A12+A1+A2+A13
EN 60335-1:2012+A11+A13
EN 62233:2008
AfPS GS 2014:01

CE (LVD) Conformity tested according to: EN 60335-2-40:2003+A11+A12+A1+A2+A13
EN 60335-1:2012+A11+A13
EN 62233:2008

EMC conformity tested according to: EN 55014-1:2017
EN 55014-2:2015
EN 61000-3-2:2014
EN 61000-3-3:2013

Correct disposal of this product:

Within the EU, this symbol indicates that this product should not be disposed of with household waste. Old appliances contain valuable recyclable materials that should be recycled. In addition, the environment or human health should not be harmed by uncontrolled waste disposal. Therefore, please dispose of old appliances via suitable collection systems or send the appliance for disposal to the place where you bought it. They will then recycle the appliance.

I wish you much pleasure with this appliance.

Your Aktobis AG

Keep these instructions for use in a safe place !

Notes:
